

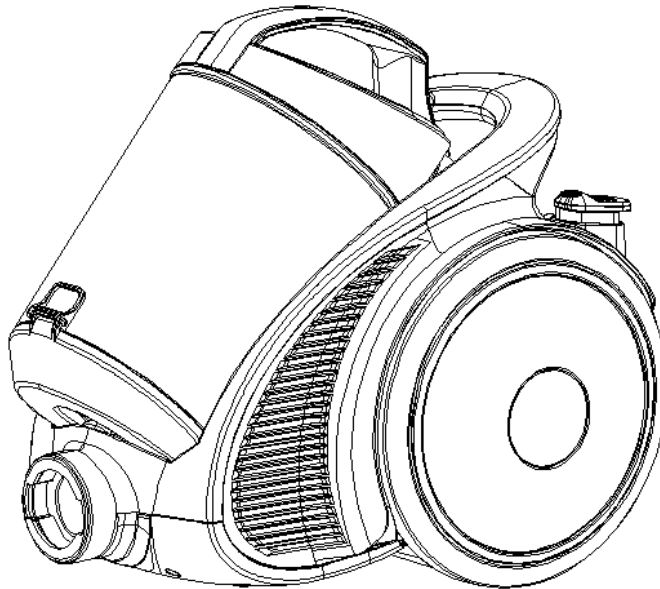

# Russell Hobbs

At the heart of your home

## Turbo Cyclonic Pro Bagless Cylinder Vacuum Cleaner



**Model Number: RHCV2002**

For Customer Services & Spare Parts please call **0345 209 7461**  
Opening times: Monday - Friday 8am – 8pm & Saturday 9am – 1pm  
Or visit us at [www.productcareuk.com](http://www.productcareuk.com)

**PLEASE RETAIN FOR FUTURE  
REFERENCE**

# CONTENTS

	Page(s)
Safety instructions	3-6
Energy performance label	7
Vacuum feature diagram	8
Vacuum cleaner assembly	9-10
Using your vacuum cleaner	11-13
Cleaning and care	14-16
Problem solving	17
Guarantee and customer services	18
Spare parts	19
Connection to the mains supply	20-21
Disposal information	24

Thank you for purchasing your Russell Hobbs Turbo Cyclonic Pro Bagless Cylinder Vacuum Cleaner.

To get the best from your new cleaner, take a few moments to read these instructions and keep them in a safe place for future reference.

Should you require any further assistance, our friendly Product Care team will be happy to help.

For Customer Services & Spare Parts please call **0345 209 7461**  
Opening times: Monday - Friday 8am – 8pm & Saturday 9am – 1pm  
Or visit us at **[www.productcareuk.com](http://www.productcareuk.com)**



# **SAFETY INSTRUCTIONS**

## **IMPORTANT SAFETY INSTRUCTIONS** **READ CAREFULLY AND KEEP FOR FUTURE REFERENCE**

### **WARNING:**

- It is hazardous for anyone other than a competent person to carry out any service or repair operation that involves the removal of a cover which gives protection against exposure to electrical parts.
- If the supply cord is damaged, it must be replaced by the manufacturer, its service agent or similarly qualified persons in order to avoid a hazard.
- This product is intended for household use only. Do not use outdoors.
- This appliance can be used by children aged from 8 years and above and persons with reduced physical, sensory or mental capabilities or lack of experience and knowledge IF they have been given supervision or instruction concerning use of the appliance in a safe way and understand the hazards involved. Children shall not play with the appliance. Cleaning and user maintenance shall not be made by children unless they are older than 8 and supervised. Keep the appliance and its' cord out of reach of children less than 8 years.
- Do not operate this appliance for anything other than its intended use. This product is intended for household use only. Do not use outdoors.
- Do not immerse in water or other liquids for cleaning.

# **SAFETY INSTRUCTIONS**

## **IMPORTANT SAFETY INSTRUCTIONS**

### **READ CAREFULLY AND KEEP FOR FUTURE REFERENCE**

- Do not direct at people, animals, electrical outlets, or equipment containing electrical components.
- Unplug from outlet when not in use. Do not leave the cleaner unattended while plugged in.
- Do not use with damaged cord or plug.
- Do not use vacuum cleaner if it has been dropped, damaged, left outdoors or dropped into water.
- Keep the vacuum cleaner away from water; do not allow it to get wet. If unit is wet, do not plug unit into wall socket or turn unit on.
- Do not handle the vacuum cleaner with wet hands.
- Do not pull or carry by cord, use cord as a handle, close door on cord, pull cord around sharp corners or edges, or expose cord to heated surfaces.
- Do not unplug by pulling on cord.
- To protect against electrical shock do not immerse cord, plug, or appliance in water or other liquid.
- Unplug from the mains outlet when not in use, before putting on and taking off parts, and before cleaning.
- The use of accessory attachments not recommended by the appliance manufacturer may cause fire, electric shock or injury. Only use the accessories supplied by the manufacturer.

# **SAFETY INSTRUCTIONS**

## **IMPORTANT SAFETY INSTRUCTIONS** **READ CAREFULLY AND KEEP FOR FUTURE REFERENCE**

### **WARNING:**

- Do not let the cord hang over the edge of the worktop, or touch hot surfaces.
- This cleaner is intended for internal household use only, do not use outside or for anything other than its' intended purpose.
- Do not use this vacuum to pick up water or any other liquids, combustible substances or hot/burning objects.
- Only use the unit when fully assembled.
- Never place your fingers or other objects into any part of the cleaner. Be aware that loose clothing or hair may become trapped in the cleaner if improperly used.
- Before use, ensure that all of the air vents of the cleaner are clear and there is no restriction of air flow.
- When cleaning stairs, ensure the cleaner is on a step below you. NEVER place the cleaner above.
- Caution: Exhaust air discharged from the rear of the cleaner may extinguish a gas fire, pilot light, or disturb ashes in an open fire. Always avoid directing the cleaner toward naked flames.

# SAFETY INSTRUCTIONS

## **IMPORTANT SAFETY INSTRUCTIONS** **READ CAREFULLY AND KEEP FOR FUTURE REFERENCE**

- **Important:** This cleaner has a thermal safety device which automatically cuts off the power supply in case of over heating. If the safety device has switched the cleaner off, unplug from the mains, allow the cleaner to cool down and check for any blockages. Once the cleaner has cooled it can be plugged back in to the mains and used as normal.

For Customer Services & Spare Parts please call **0345 209 7461**  
Opening times: Monday - Friday 8am – 8pm & Saturday 9am – 1pm  
Or visit us at **[www.productcareuk.com](http://www.productcareuk.com)**



# ENERGY PERFORMANCE LABEL

The purpose of the energy label is to help you understand a vacuum cleaner's energy efficiency performance.

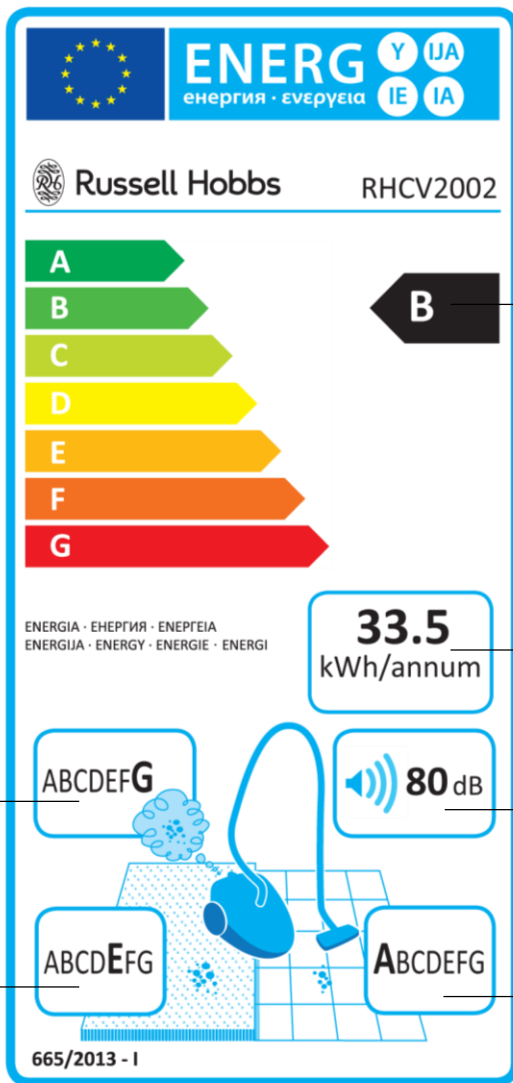

**1. Energy rating** – based primarily on energy consumption and pick-up.

**2. Annual energy usage** – the amount of energy used over a year.

**3. Emissions** – the amount of dust in the air emitted from the machine's exhaust.

**4. Noise** – the noise level produced by the machine, measured in decibels.

**5. Pick up (carpets)** – the rating of how much dust the machine picks up from carpets.

**6. Pick-up (hard floors/crevices)** – the rating of how much dust the machine picks up from hard floors and crevices.

# VACCUUM FEATURE DIAGRAM

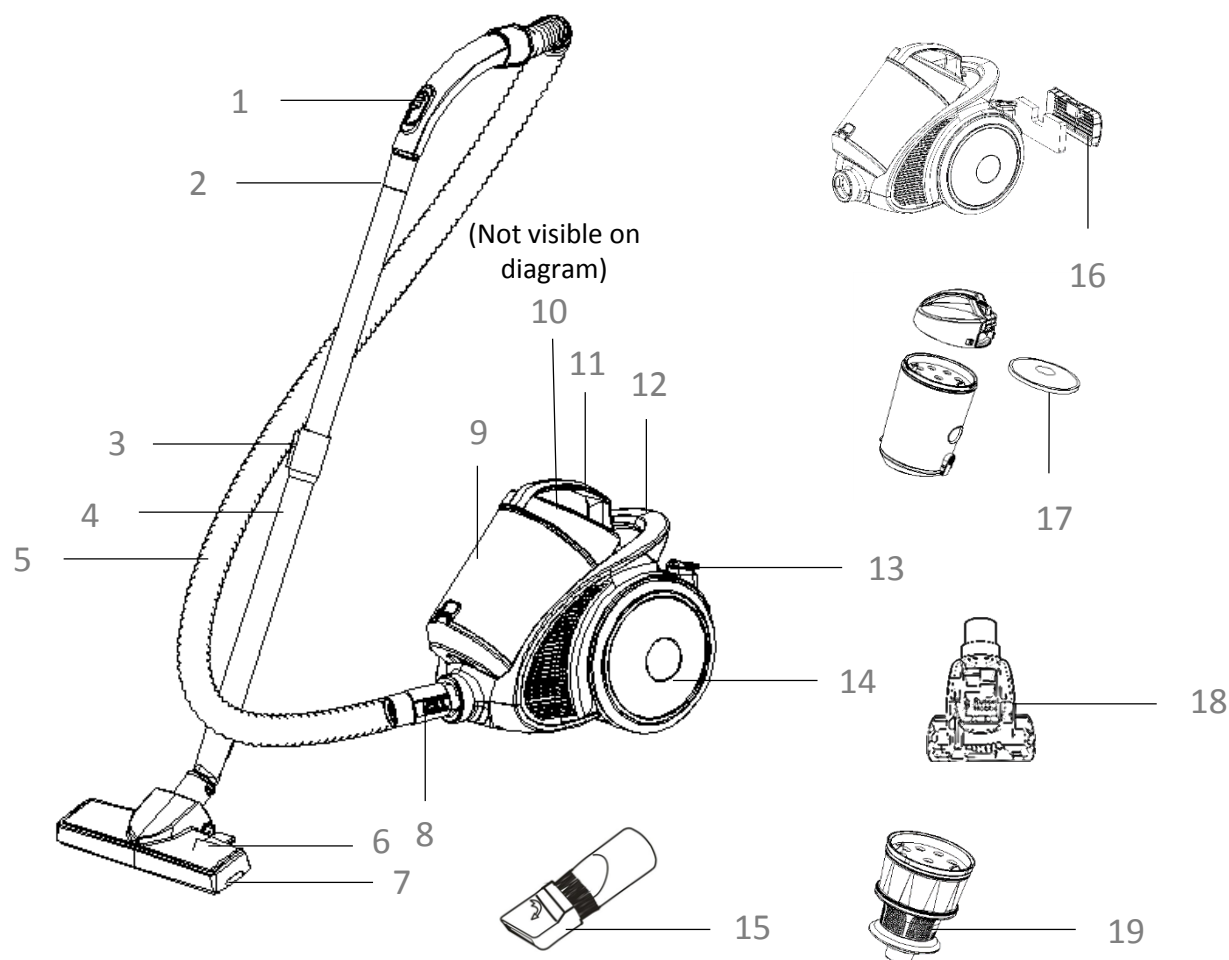

- |          |                        |           |                          |           |                           |
|----------|------------------------|-----------|--------------------------|-----------|---------------------------|
| <b>1</b> | Hose suction control   | <b>7</b>  | Floor head               | <b>13</b> | Power button              |
| <b>2</b> | Hose connector         | <b>8</b>  | Hose attachment clip     | <b>14</b> | Wheel                     |
| <b>3</b> | Extension lock         | <b>9</b>  | Dust container           | <b>15</b> | 2 in 1 crevice tool       |
| <b>4</b> | Extension tube         | <b>10</b> | Cord release button      | <b>16</b> | External filter and cover |
| <b>5</b> | Hose                   | <b>11</b> | Container release button | <b>17</b> | Dust container filter     |
| <b>6</b> | Floor surface selector | <b>12</b> | Carry handle             | <b>18</b> | Turbo brush tool          |
|          |                        |           |                          | <b>19</b> | Multi cyclonic filter     |

For Customer Services & Spare Parts please call **0345 209 7461**  
 Opening times: Monday - Friday 8am – 8pm & Saturday 9am – 1pm  
 Or visit us at [www.productcareuk.com](http://www.productcareuk.com)



# VACUUM CLEANER ASSEMBLY

## **Before using your vacuum cleaner**

Remove all packaging and lay out the separate components.

Check the unit after unpacking for any visual damage such as:

- Misaligned or damaged parts
- Damage to the main body and separate components
- Damage to the plug or cable.

If you can see any damage do not use the vacuum cleaner and contact customer services.

For Customer Services & Spare Parts please call **0345 209 7461**  
Opening times: Monday - Friday 8am – 8pm & Saturday 9am – 1pm  
Or visit us at [www.productcareuk.com](http://www.productcareuk.com)

# VACUUM CLEANER ASSEMBLY

**Ensure the unit is unplugged before assembling.**

**1.** Place the dust container onto the unit, base first, then tilt forward to engage the top.

**Note:** Do not carry the unit with the dust container.

**2.** Insert the hose connector into the hose outlet, aligning the grooves in the outlet with the clips on the connector. Push in until it 'clicks' to secure.

**3.** Insert the extension tube into the hose connector and push together.

**4.** Insert the extension tube into the floor head and rotate if necessary.

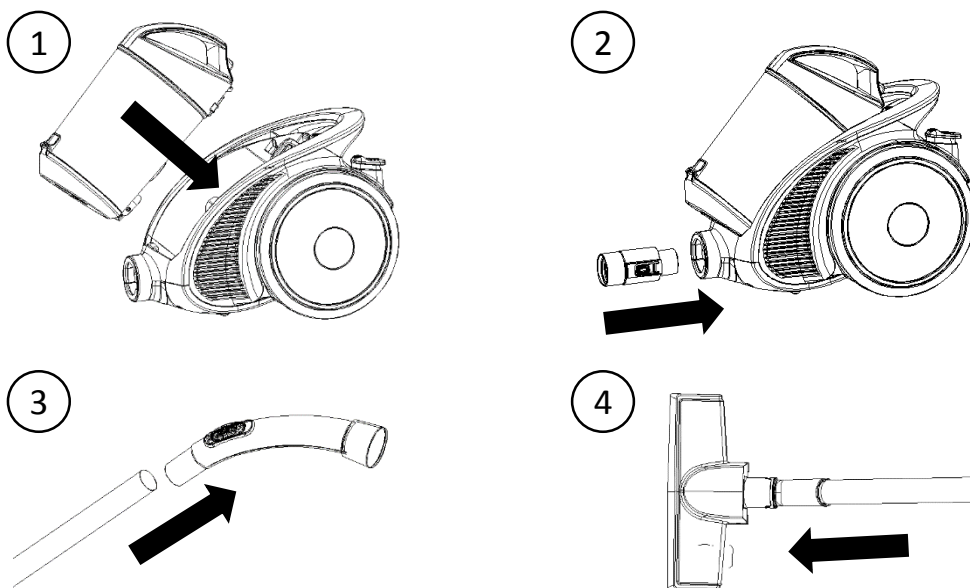

# USING YOUR VACUUM CLEANER

Once assembled:

1. The cord is stored inside the unit. Pull the power cord out of the machine to as long as you require and stop when you see the yellow tab. Do not over-extend. If the red tab is visible, then wind the cord back until only the yellow tab is visible.
2. Plug the cable into a wall socket and press the switch on.
3. Press the power button to start vacuuming.
4. Move the vacuum cleaner floor head in a forwards and backwards motion over the areas you would like to clean.

**Note:** Large items can get trapped in the brush/floor head which could cause the unit to overheat. Make sure you pick up larger items that could get trapped before vacuuming.

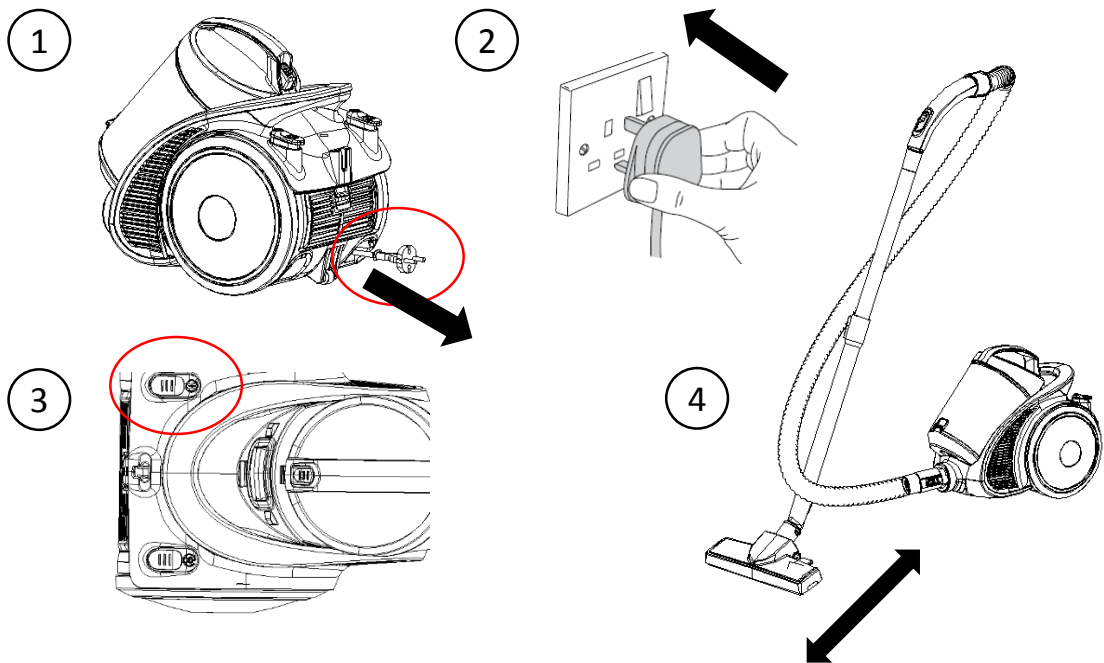

# USING YOUR VACUUM CLEANER

**5.** You can adjust the extension tube length to a comfortable cleaning height. To alter the length of the telescopic handle,

a) Press and hold the extension lock in the direction indicated.

b) Slide the steel pole, up or down, to the correct length.

**6.** Another adjustment you can make is to the suction power of the floor head. To use less suction power, move the suction control tab in the direction indicated. For maximum suction power, close the tab.

\* The 2 in 1 crevice/brush tool is for narrow gaps and hard to reach places.

\* The turbo brush is for use on upholstery and is also ideal for the retrieval of pet material or human hair across wide areas of carpet.

**7.** Both attach to either the extension tube or the hose connector in the same manner as the floor head.

**8.** To adapt the tool for use as a brush on delicate surfaces, rotate the head of the tool in the direction indicated until it extends out.

**9.** When using the floor head you can adapt the brush depending on floor type. To clean on hard floors, push the surface selector in so the icon shows a brushed head (refer to diagram.)

**10.** To clean on carpets, push the surface selector down so the icon shows a smooth head (refer to diagram.)

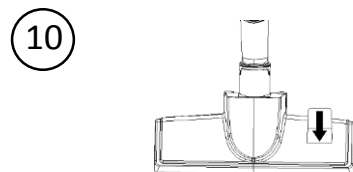
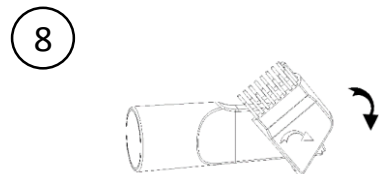
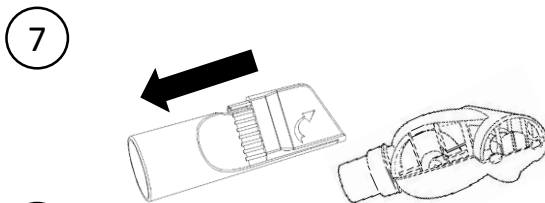
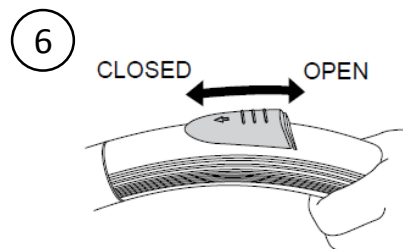
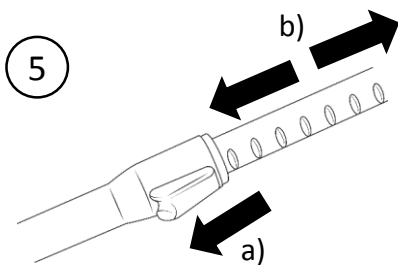

# USING YOUR VACUUM CLEANER

## Emptying the dust container

When the dust container starts to fill it will need to be emptied.

1. To remove the dust container, press the release button located at the top of the lid handle.
2. Lift the container away from the unit base.
3. Locate the bin release button on the cover at the back of the container.
4. Over a bin, push the release button to open the base of the container. You may need to tap the sides to empty all of the dirt. Close the base to secure.

### Important:

You may wish to empty the dust container outdoors as emptying may create a dust cloud.

Place the dust container onto the unit, base first, then tilt forward to engage the top.

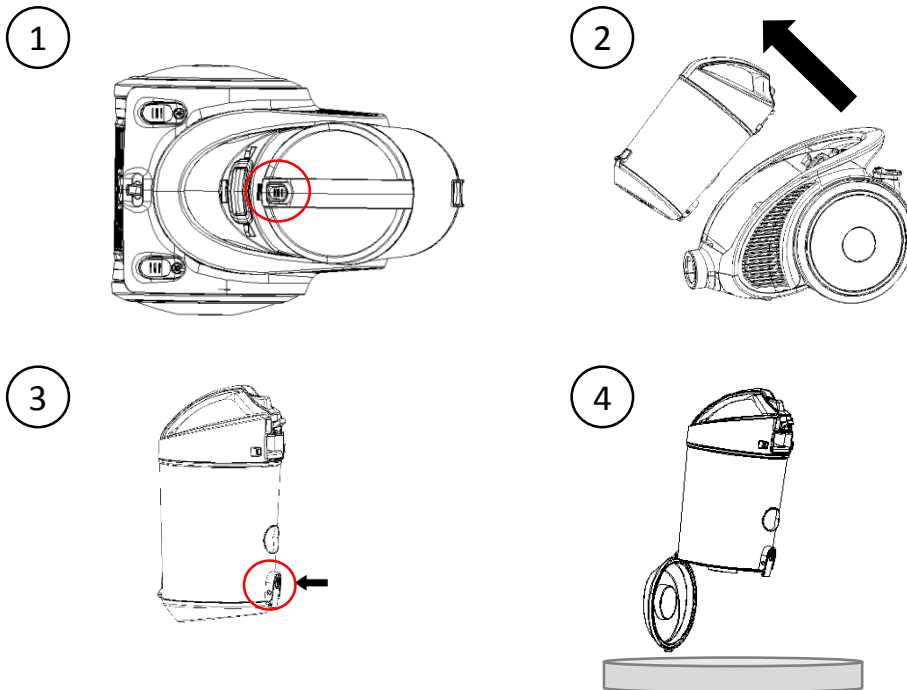

# CLEANING AND CARE: CLEANING THE FILTER

Before you clean the appliance, disconnect the mains plug from the wall socket.

Remove the filter cover on the back of the cleaner by pushing the tab downwards and pulling the cover away.

Pull the filter out of the cover and tap over a bin to remove any excess dust. Wash in warm water and allow to dry for 24 hours.

Once dried, put the filter back into the cover and refit the assembly on the back of the vacuum cleaner by pushing inwards until secure.

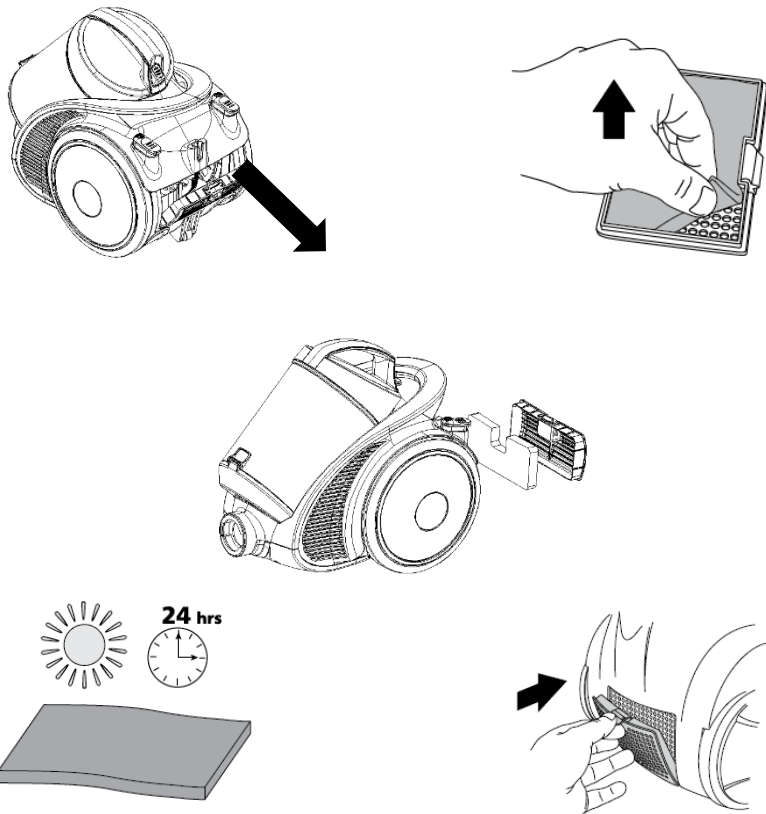

# CLEANING AND CARE:

## CLEANING THE FILTER

1. Remove the dust container and rotate the lid anti clockwise so that the arrow is pointing to the unlock symbol.
2. Remove the dust container filter and get rid of excess dirt over a bin.
3. Wash in warm water. Allow to dry for 24 hours before reinserting.
4. Once the dust container lid and filter are removed, lift out the multi cyclonic filter from the container. This comes apart further into 3 parts.
5. To remove the bottom part, turn it anticlockwise and lift off.
6. The middle part will lift off. Wash all parts including the container in water and allow to thoroughly dry before reusing.
7. To reassemble the multi cyclonic filter, lower the middle assembly onto the base and align the ribs with the grooves so that it sits in place. Lower the bottom assembly onto the middle assembly with the top assembly lip facing upwards. Align the ribs with the grooves so that it sits in place and turn clockwise to secure the assembly together.

**Note:** The filter assembly fits back into the container with the rib of the assembly slotting into the groove of the container (refer to diagram.) Make sure the dust container filter is fitted back into the top of the assembly with the lip facing downwards.

Reinsert the lid onto the container with the arrow pointing to the unlock symbol. To secure, turn clockwise so the arrow points to the lock symbol.

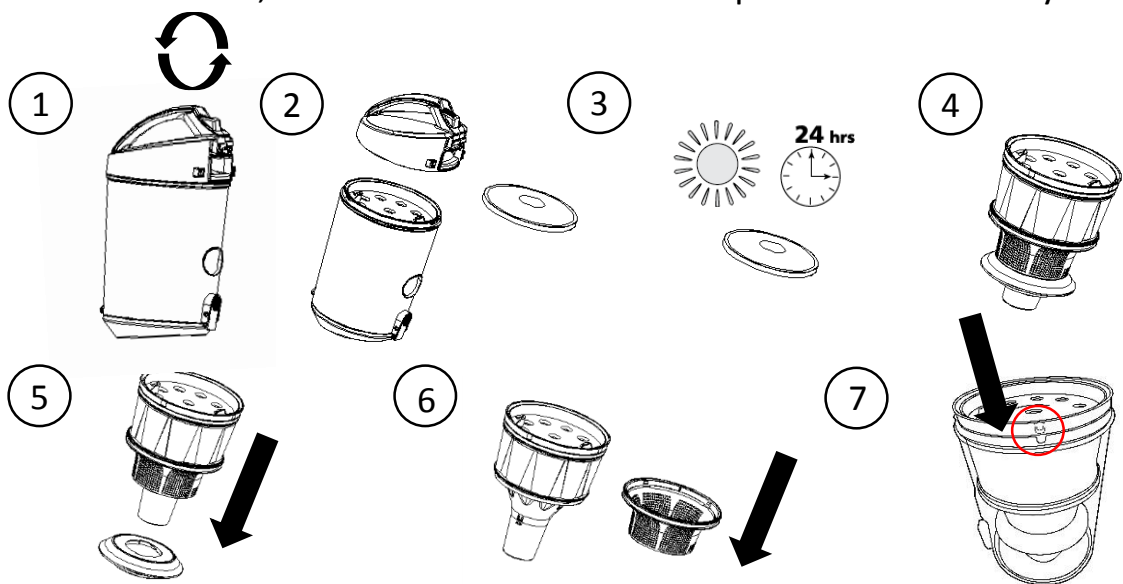

# CLEANING AND CARE

Before you clean the appliance, disconnect the mains plug from the wall socket.

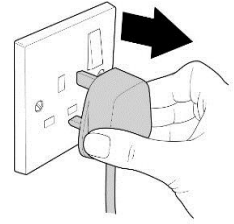

## Disassembly

1. Press the cord rewind button to automatically bring the cord back inside the unit for storage.
2. To remove the extension hose, manoeuvre it away from the hose connector.
3. To remove the floor head/accessory, pull the extension tube/hose connector away from the head/accessory – you may need to ease it off.
4. To remove the hose, press the tabs on the sides of the hose attachment clip and pull the hose away from the unit.

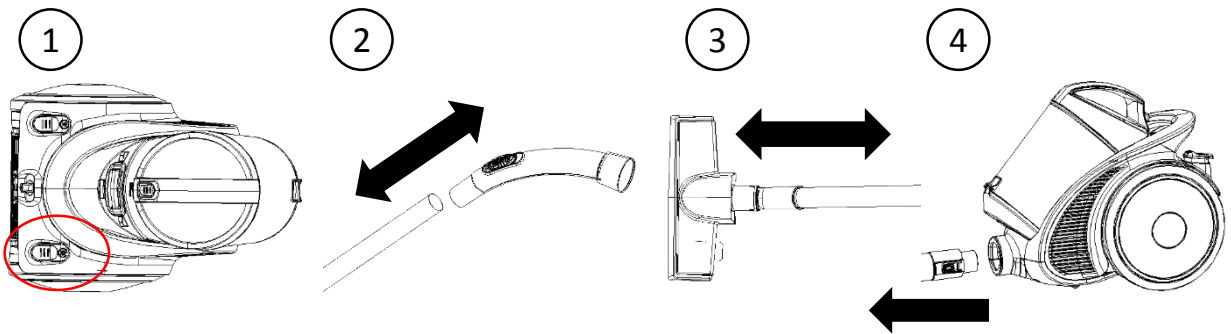

To clean the exterior of the device, use a damp, soft cloth and mild detergent.

**NEVER IMMERSE THE VACUUM IN WATER.**

Wash non-electrical removable accessories in warm soapy water and allow to dry thoroughly before next use.

If the vacuum is damaged, contact the customer service helpline using the details at the bottom of this page.

## Storage

Store in a clean and dry environment.

For Customer Services & Spare Parts please call **0345 209 7461**  
Opening times: Monday - Friday 8am – 8pm & Saturday 9am – 1pm  
Or visit us at [www.productcareuk.com](http://www.productcareuk.com)



# PROBLEM SOLVING

<b><u>PROBLEM</u></b>	<b><u>POSSIBLE PROBLEM</u></b>	<b><u>POSSIBLE SOLUTION</u></b>
<b><i>The vacuum cleaner is plugged in but does not work</i></b>	Power cord/plug damage	Check the power cord and plug for signs of damage.
	Fuse is damaged	Check and replace the fuse in the plug.
<b><i>The suction is decreasing and the vacuum is not picking up dirt</i></b>	Dust container	Check if the dust container is full, if so, empty it.
	Filters are dirty	Clean the filters.
	Hose/head blockages	Check that there are no blockages in the hose or cleaning head.
<b><i>Vacuum cleaner is over heating</i></b>	Filters are dirty	Check that the filters are not blocked, if so, clean them following the instructions in this booklet.
<b><i>Automatic power cord rewind does not fully rewind the power cord</i></b>		Pull the power cord fully out and press the rewind button again.
<b><i>Dust is coming out of the vacuum cleaner</i></b>	Dust container fitting	The dust container has not been fitted correctly. Refit the container following the instructions in this booklet.
<b><i>The air coming out of the vacuum cleaner smells</i></b>	Filters are dirty	Clean the filters. Also clean the hose and dust container
	Filters are not dry	Ensure the filters have been left to dry for 24 hours before refitting back into the vacuum cleaner and using.

**We're here should you need us.**

For Customer Services & Spare Parts please call 0345 209 7461  
 Opening times: Monday - Friday 8am – 8pm & Saturday 9am – 1pm  
 Or visit us at [www.productcareuk.com](http://www.productcareuk.com)

# **GUARANTEE AND CUSTOMER SERVICES**

At Russell Hobbs, we take all our customer feedback seriously.

**Feel free to contact our Product Care Team, on 0345 209 7461  
Monday – Friday: 8am-8pm & Saturday: 9am – 1pm,  
who will be more than happy to assist you.**

This product is guaranteed for **12 months** from the date of the original purchase. If any defect arises due to faulty materials or workmanship, the faulty product must be returned to the place of purchase.

Refund or replacement is at the discretion of the retailer.

## **The following conditions apply:**

- The product must be returned to the retailer with the original proof of purchase.
- The product must be installed and used in accordance with the instructions contained in this instruction guide and any other instructions for use which are supplied.
- It must be used for domestic purposes only and for its intended use.
- This warranty does not cover wear and tear, damage, misuse or consumable parts.

**This does not affect your statutory rights.**

For Customer Services & Spare Parts please call **0345 209 7461**  
Opening times: Monday - Friday 8am – 8pm & Saturday 9am – 1pm  
Or visit us at [www.productcareuk.com](http://www.productcareuk.com)

# SPARE PARTS

To check the availability of the following spare parts, simply contact our friendly Customer Services team using the details provided at the bottom of this page.

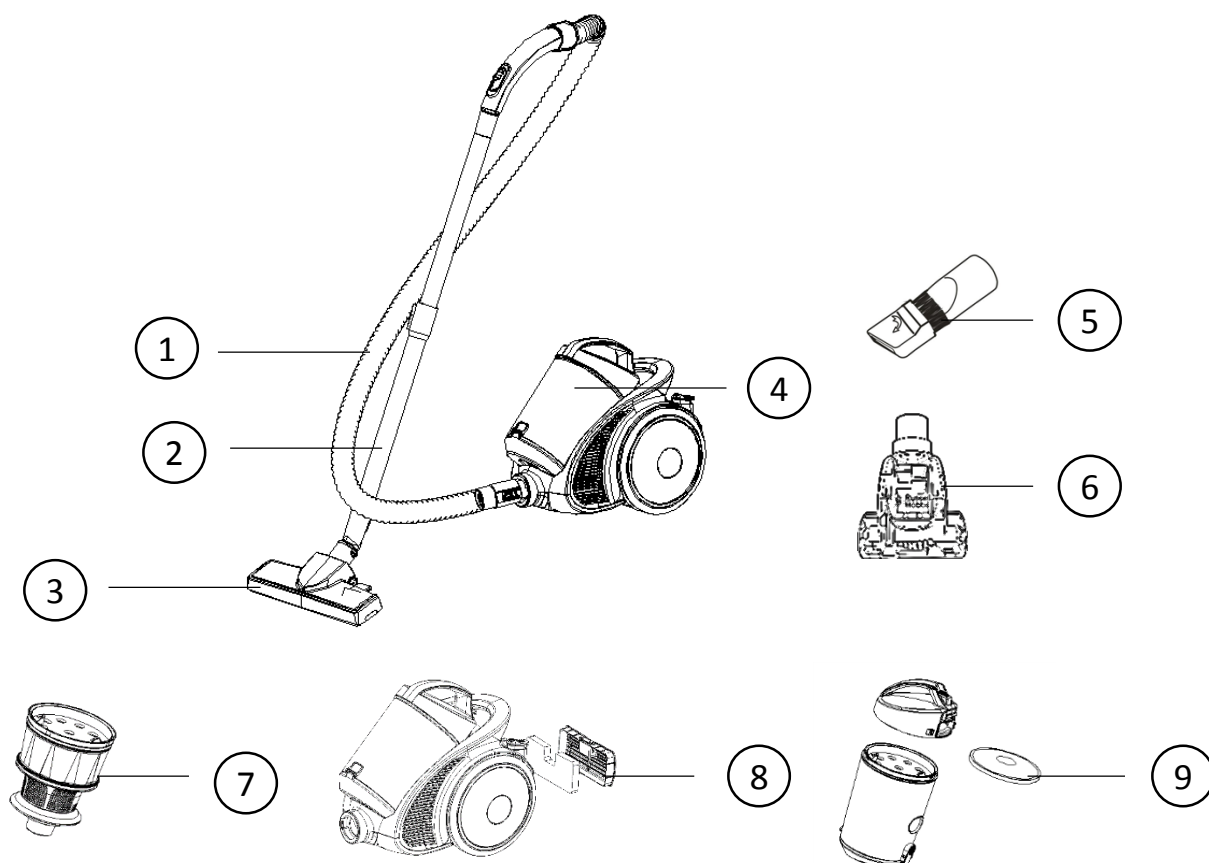

- |   |                     |   |                           |
|---|---------------------|---|---------------------------|
| 1 | Hose                | 6 | Turbo brush               |
| 2 | Extension tube      | 7 | Multi cyclonic filter     |
| 3 | Floor head          | 8 | External filter and cover |
| 4 | Dust container      | 9 | Dust container filter     |
| 5 | 2 in 1 crevice tool |   |                           |

For Customer Services & Spare Parts please call **0345 209 7461**  
Opening times: Monday - Friday 8am – 8pm & Saturday 9am – 1pm  
Or visit us at [www.productcareuk.com](http://www.productcareuk.com)

# CONNECTION TO THE MAINS SUPPLY

## **WARNING- THIS APPLIANCE MUST BE EARTHED**

This appliance is designed to operate from a mains supply of  
220-240V~ 50Hz.

Check that the voltage marked on the product corresponds  
with your supply voltage.

This product is fitted with a 13A plug complying with BS1363.  
If this plug is unsuitable or needs to be replaced, refer to customer  
services.

Important: The wires in the mains lead are coloured in  
accordance with the following code:

**GREEN/YELLOW** – EARTH

**BLUE** - NEUTRAL

**BROWN** – LIVE

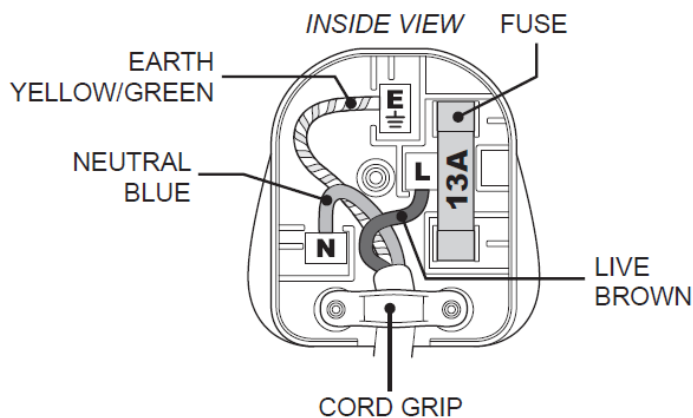

# CONNECTION TO THE MAINS SUPPLY

## For UK use only – PLUG

- As the colours of the wires in the mains lead of this appliance may not correspond with the coloured markings identifying the terminals in your plug, proceed as follows:
- The **GREEN/YELLOW** wire is the EARTH and must be connected to the terminal which is marked with the letter E or by the earth symbol or coloured **GREEN** or **GREEN/YELLOW**.
- The **BLUE** wire is the NEUTRAL and must be connected to
- the terminal marked with the letter N or coloured **BLACK**.
- The **BROWN** wire is the LIVE wire and must be connected to
- the terminal marked with the letter L or coloured **RED**.
- **Always ensure that the plug cord grip is fastened correctly.**
- If a 13A (BS1363) fused plug is used it must be fitted with a
- 13amp fuse conforming to BS1362 and be BSI or ASTA approved.

If the fuse cover is lost the plus must not be used until a replacement is obtained from an electrical supplier.

If you need to remove the plug, cut it from the mains lead and dispose of it. NEVER attempt to re-use this plug or insert it into a socket outlet, as there is a very great risk of electrical shock.

# NOTES

A large, empty rectangular box with rounded corners and a thin green border, intended for taking notes.

# NOTES

A large, empty rectangular box with rounded corners and a thin green border, intended for taking notes.



# Russell Hobbs

At the heart of your home

For Customer Services & Spare  
Parts please call

**0345 209 7461**

Opening times: Monday - Friday  
8am – 8pm & Saturday 9am – 1pm

Or visit us at

**[www.productcareuk.com](http://www.productcareuk.com)**

Revision 1a

Model: **RHCV2002**

Produced for:

**G2S Ltd,**

**Wigan,**

**WN2 4AY**

**CE**



This symbol is known as the 'Crossed-out wheellie bin Symbol'. When this symbol is marked on a product/batteries, it means that the product/batteries should not be disposed of with your general household waste. Only discard electrical/electronic/battery items in separate collection schemes, which cater for the recovery and recycling of materials contained within. Your co-operation is vital to ensure the success of these schemes and for the protection of the environment. For your nearest disposal facility, visit [www.recycle-more.co.uk](http://www.recycle-more.co.uk) or ask in store for details.

We reserve the right, due to possible changes to design, to alter the instruction manual without prior notice.

